



Product manual

Compact apartment VAV unit

CAVU

Airflow regulation

Version 1.0.4
Date: 12.10.2022

CAVU

Compact apartment VAV unit (CAVU) is used for air regulation in areas with high demand for comfort and low noise. It is mainly used in residential or office buildings with central air preparation. CAVU consists of two VAV units (supply and extract) with integrated silencers.

Optional CAVU-S unit, with more compact dimensions is possible.



- ▼ [Product overview](#)
- ▼ [Ordering key](#)
- ▼ [Accessories](#)
- ▼ [Actuators](#)
- ▼ [Parametrization](#)
- ▼ [Diagrams](#)
- ▼ [Maintenance](#)



- Compact (all in one) casing
- Minimal installation cost
- Adjustable air volume
- Maintenance-free
- Low sound power levels
- Energy saving (demand controlled)
- Indoor air quality improvement
- Simple and easy to use
- Wide variety of control modes
- Protocols: MPBUS, MODBUS, BACNET, KNX

DIMENSIONS

VAV ϕ d [mm]	B [mm]	H [mm]	L [mm]
125	490	230	1700
160	535	260	1700

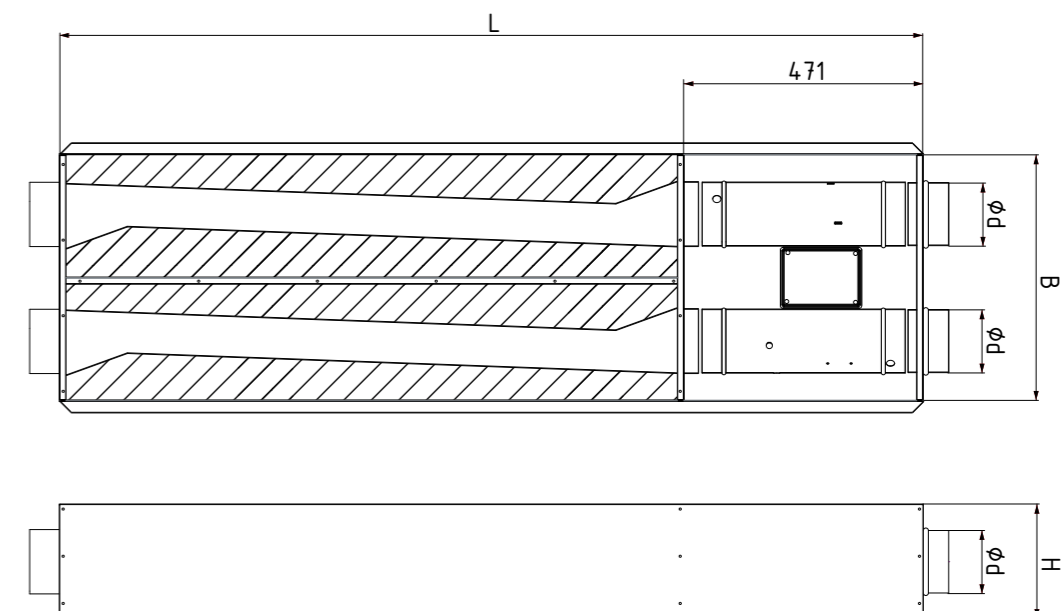

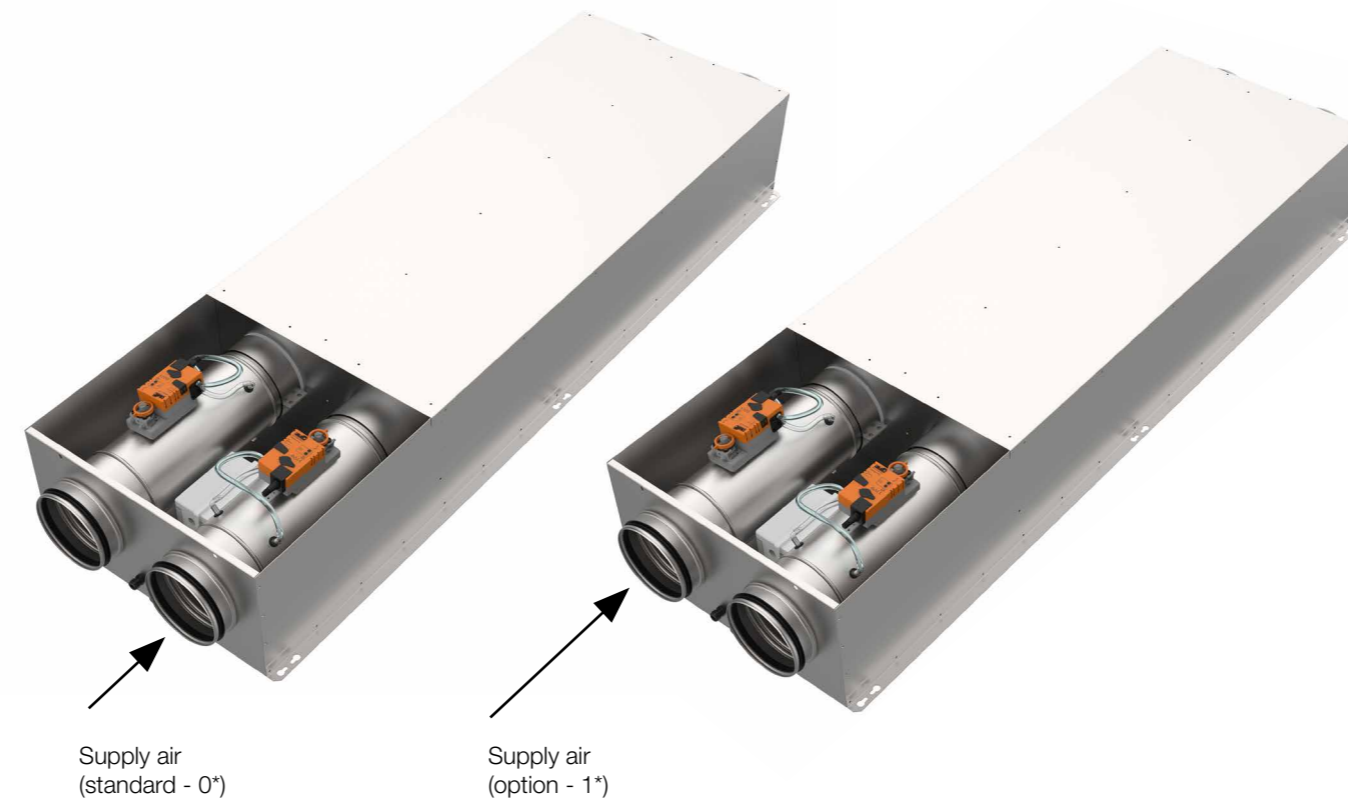

- ▼ [Product overview](#)
- ▼ [Ordering key](#)
- ▼ [Accessories](#)
- ▼ [Actuators](#)
- ▼ [Parametrization](#)
- ▼ [Diagrams](#)
- ▼ [Maintenance](#)



ORDERING KEY / CAVU

AIRFLOW REGULATION

ORDERING KEY

- (1) Compact apartment VAV unit
- (2) Diameter
- (3) Communication type
- (4) Supply air side

CAVU - ød - MP - 0

- (1) CAVU
- (2) Diameter **ød**
- (3) Communication type
 - MP** - Belimo LMV/NMV MP
 - MF** - Belimo LMV/NMV MF
 - SGB** - Siemens GDB/GLB
 - MOD-S** - Siemens GDB/GLB MOD
 - MOD/BAC** - Belimo LMV/NMV MOD
 - KNX-S** - Siemens GDB/GLB KNX
 - KNX** - Belimo LMV/NMV KNX
 - BAC** - Siemens GDB/GLB BA
 - PP** - Gruner 327V
 - MOD-G** - Gruner 327MODBUS
- (4) Supply air side
 - 0** - Supply air right / Extract air left
 - 1** - Supply air left / Extract air right

BELIMO ZTH

Adjustment device ZTH-EU and NFC for VAV terminal units with Belimo volume flow controllers, used to facilitate service and commissioning.

ORDERING KEY: RVPA-ZTH-EU



Gruner GUIV3-M

Adjustment device GUIV3-M for VAV terminal units with Gruner volume flow controllers, used to facilitate service and commissioning.

ORDERING KEY: RVPA-GUIV3-M



Siemens AST20

Adjustment device Type AST20 for VAV terminal units with Siemens volume flow controllers, used to facilitate service and commissioning.

ORDERING KEY: RVPA-AST20



- ▼ [Product overview](#)
- ▼ [Ordering key](#)
- ▼ [Accessories](#)
- ▼ [Actuators](#)
- ▼ [Parametrization](#)
- ▼ [Diagrams](#)
- ▼ [Maintenance](#)



ACCESSORIES

ORDERING KEY ACCESSORIES

(1) Type (2) Built in sensor (3) Protocol

RVPA-AST20 - H - B

- (1) **RVPA-ZTH-EU**
RVPA-GUIV3-M
RVPA-AST20
- (2) **C** - CO2 sensor
H - Humidity sensor
CH - CO2 and humidity sensor
- (3) **B/RS** - BACNet

Belimo motor drive



- motor drives : Belimo (MP, ModBus/Bacnet, MF, KNX)
- power supply - AC 24V, 50/60 Hz
- DC 24V
- diagnostic socket for service and PC-Tool software

Version

Type	Torque	Energy consumption	Dimensioning	Weight
LMV-D3-MP	5Nm	2W	4VA (max- 8A @ 5ms)	≈ 500g
NMV-D3-MP	10Nm	3W	5VA (max- 8A @ 5ms)	≈ 700g
LMV-D3-MOD/BAC	5Nm	2W	4VA (max- 8A @ 5ms)	≈ 500g
NMV-D3-MOD/BAC	10Nm	3W	5VA (max- 8A @ 5ms)	≈ 700g
LMV-D3-MF	5Nm	2W	4VA (max- 8A @ 5ms)	≈ 500g
LMV-D3-KNX	5Nm	2W	4VA (max- 8A @ 5ms)	≈ 500g
NMV-D3-KNX	10Nm	3W	5VA (max- 8A @ 5ms)	≈ 700g

Control variables

V_{nom}	specific nominal volume flow, suitable for VAV units
$\Delta p @ V_{nom}$	50...450 Pa
V_{max}	20...100%
V_{min}	0...100%
V_{mid}	50% od V_{min} do V_{max}

Classic control

VAV mod for referent variables Y (connection 3)	- DC 2...10V / (4...20mA with 500Ω impedance) - DC 0...10V / (0...20mA with 500Ω impedance) - Adjustable DC 0...10V	}input impedance min. 100 kOhm
Actual signal value mod U5 (connection 5)	- DC 2...10V - DC 0...10V - Adjustable : volume flow, damper position or differential pressure	} max. 0.5 mA
CAV mode (constant volume flow)	CLOSED / V_{min} / V_{mid} / V_{max} / OPEN* (*only with AC 24V supply)	

Actuator

Connection	Cable, 4 x 0,75 mm ²
Protection	
Safety class	III Safety extra - low voltage
Level of protection	IP54
Electromagnetic compliance	CE according to 89/336/EEC
Mode	Type 1 (according to EN 60730-1)
Rated power	0,5kV (according to EN 60730-1)
Operating temperature	0...+50°C
Non operating temperature	-20...+80°C
Relative humidity	5...95% r.h., no condensation (according to EN 60730-1)
Maintainance	Not required

- ▼ [Product overview](#)
- ▼ [Ordering key](#)
- ▼ [Accessories](#)
- ▼ [Actuators](#)
- ▼ [Parametrization](#)
- ▼ [Diagrams](#)
- ▼ [Maintanace](#)



ACTUATORS

Operation specification:

Rated voltage	DC 15 V (from regulator VRP..)		
Voltage range	DC 13,5...16,5 V		
Mesuring range	0...100 Pa 0...300 Pa 0...600 Pa		
Mesuring principle	Inductive membrane differential pressure measurement		
Output signal	DC 0...10 V (proportional pressure for VRP..)		
Linearity	±1% from extreme value (FS)		
Histeresis	0.1% typ.		
Temperature influence			
zero position	±0.1% / K	±0.05% / K	±0.05% / K
Mesuring range	±0.1% / K t = +10...+40°C (referent temperature to = 5°C)		
Installation position	Vertical		
Position dependance	Max. ±4,5 Pa za 90° rotation from horizontal		
Electric connection	Cable 1 m , with 4 pole connector		
Protection class	III (safety extra-low voltage) IP4		
Operating temperature	0...+50°C		
Storage temperature	- 0...+80°C		
Humidity test	to EN 60335-1		

- ▼ [Product overview](#)
- ▼ [Ordering key](#)
- ▼ [Accessories](#)
- ▼ [Actuators](#)
- ▼ [Parametrization](#)
- ▼ [Diagrams](#)
- ▼ [Maintanace](#)

Wiring diagram

Analogue control signal

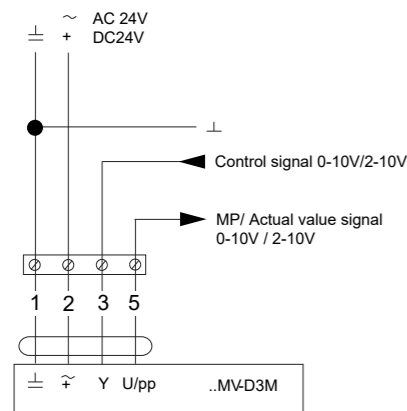

Analogue control signal supply/extract in paralel mode

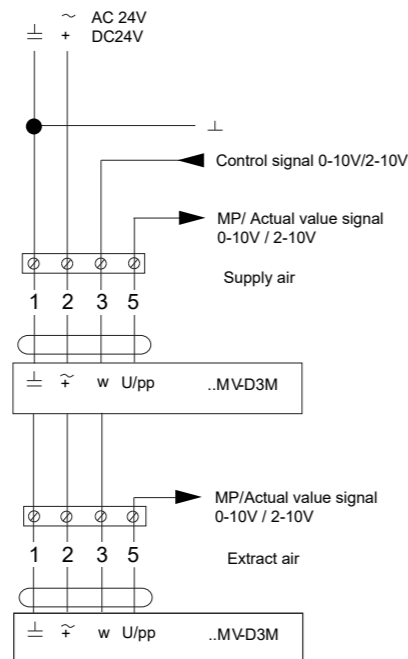

Analogue control signal master / slave mode

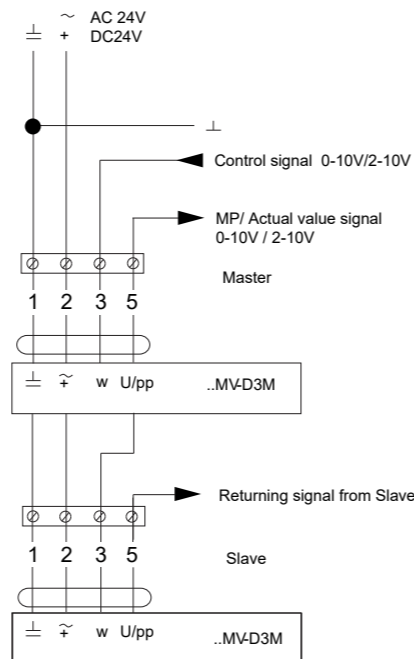

Constant mode:
- Standard 0,1V closing

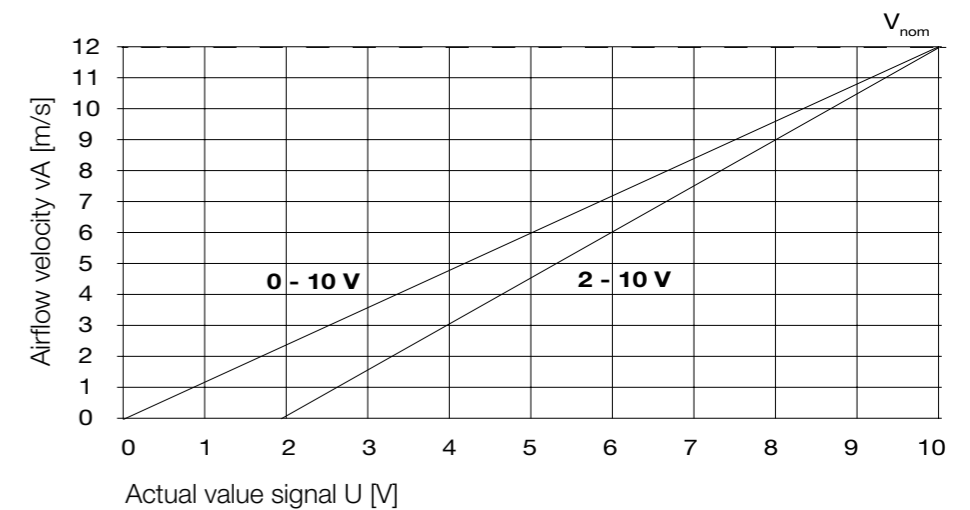
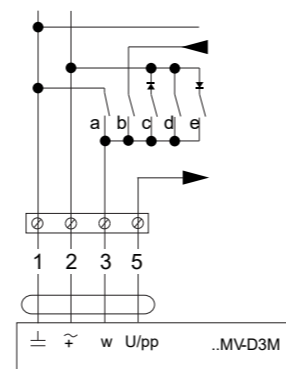

$$0 - 10 \text{ V} \quad v_{act} = \frac{U_{act} - V_{nom}}{10}$$

$$2 - 10 \text{ V} \quad v_{act} = \frac{U_{act} - 2}{8} * V_{nom}$$

ACTUATORS



Siemens motor drive

- motor drives : Siemens (KNX, ModBus, Bacnet, Analogue)
- power supply - AC 24 V ±20% 50/60 Hz

Version

Type	Torque	Energy consumption	Dimensioning	Weight
GDB181.1E/3	5Nm	2W	4VA (max- 8A @ 5ms)	≈ 500g
GLB181.1E/3	10Nm	3W	5VA (max- 8A @ 5ms)	≈ 700g
GDB181.1E/MO	5Nm	2W	4VA (max- 8A @ 5ms)	≈ 500g
GLB181.1E/MO	10Nm	3W	5VA (max- 8A @ 5ms)	≈ 700g
GDB181.1E/BA	5Nm	2W	4VA (max- 8A @ 5ms)	≈ 500g
GLB181.1E/BA	10Nm	3W	5VA (max- 8A @ 5ms)	≈ 700g
GDB181.1E/KN	5Nm	2W	4VA (max- 8A @ 5ms)	≈ 500g
GLB181.1E/KN	10Nm	3W	5VA (max- 8A @ 5ms)	≈ 700g

Damper actuator

Normal torque	5 Nm (GDB) / 10 Nm (GLB)
Maximum torque	<7 Nm (GDB) / <14 Nm (GLB)
Normal rotation angle / maximum rotation angle	90° / 95° ±2°
Running time for normal rotation angle 90°	150 s (50Hz) / 125 s (60Hz)
Direction of rotation (Adjustable with e.g. ACS941)	Clockwise / Counterclockwise

Signal inputs

Input voltage	DC 0/2 ... 10 V
Max. perm input voltage	DC 35 V
Contact Sensing	
Contact open	DC 30 V contact voltage
Contact closed	DC 0 V, 8 mA contact current

Signal outputs

Output voltage	DC 0/2 ... 10 V limited to DC 12 V
Max. output current	DC ±1 mA
Time constant (actual value U)	0,05...5 s
Resolution 0.01 S / factory settin 1 s	

Degree of protection and safety class

Degree of protection acc. to EN 60529 (cf. mounting instructions)	IP54
Safety class acc. to EN 60730	6 x 0.75 mm ²

Environmental conditions

Operation / transport	IEC 721-3-3 / IEC 721-3-2
Temperature	0 ... 50°C / -25...70°C
Humidity (non-condensing)	<95% r.h. / <95% r.h.

- ▼ [Product overview](#)
- ▼ [Ordering key](#)
- ▼ [Accessories](#)
- ▼ [Actuators](#)
- ▼ [Parametrization](#)
- ▼ [Diagrams](#)
- ▼ [Maintenance](#)



ACTUATORS

Air volume controller	
3-position controller with hysteresis	
V_{max}	20 ... 100%
V_{min}	-20 ... 100%
V_{mid}	0 ... 100%
V_n	1...3.16
Differential pressure sensor	
Connection tubes (inerior diameter)	3 ... 8 mm
Measuring range	0 ... 500 Pa
Operation range	0 ... 300 Pa
Precision at 23°C, 966 mbar and optional mounting position	
Zero point	± 0.2 Pa
Amplitude	± 4.5 of the measured value
Drift	± 0.1 Pa / Year
Max. permissible operation pressure	3000 Pa
Max. permissible overload on one side	3000 Pa
Connection cable	
Cable length	0.9 m
Number of cores and cross-sectional area	6 x 0.75 mm ²

- ▼ [Product overview](#)
- ▼ [Ordering key](#)
- ▼ [Accessories](#)
- ▼ [Actuators](#)
- ▼ [Parametrization](#)
- ▼ [Diagrams](#)
- ▼ [Maintenance](#)

Wiring diagram

Supply / extract air control in operating mode "con"
 N1 GDB181.1E/3 or GLB181.1E/3
 N2 Supervisory controller, e.g. RCU5.. or RCU6.

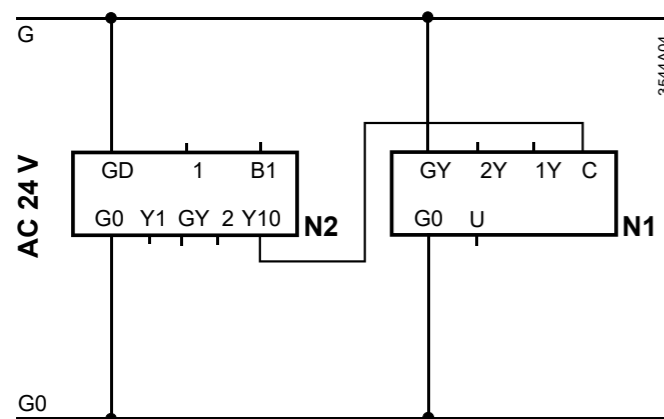

Supply / extract air control in operating mode "con"

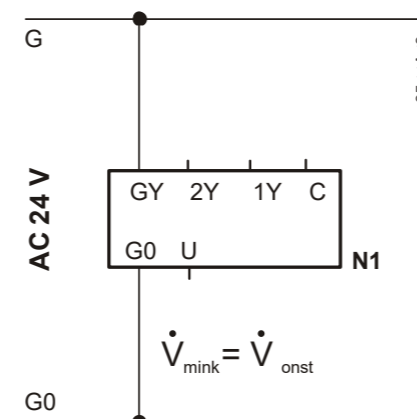

Complete shutoff in operating mode "con"
 N1 GDB181.1E/3 or GLB181.1E/3
 S1 Window switch (Window closed – switch open)

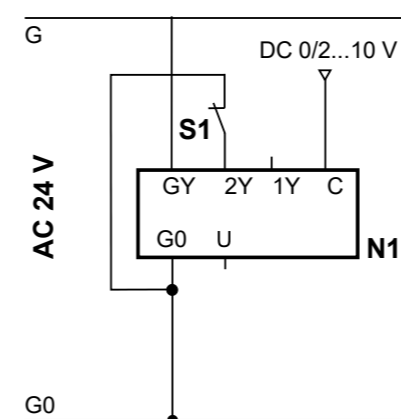

ACTUATORS



Gruner motor drive

- motor drives : Gruner (327V)
- Running time 100 s / 90°, 150 s / 90°
- Torque 5 -10 - 15 Nm
- Nominal voltage 24 VAC/DC
- Control 3 (EN 60730-1)
- Sensor 250 Pa (dynamic)
- Communication Modbus RTU

- [▼ Product overview](#)
- [▼ Ordering key](#)
- [▼ Accessories](#)
- [▼ Actuators](#)
- [▼ Parametrization](#)
- [▼ Diagrams](#)
- [▼ Maintenance](#)

Damper actuator	
Nominal voltage	24 VAC/DC, 50/60 Hz
Nominal voltage range	19...29 VAC/DC
Power consumption motor (motion)	3 W
Power consumption standby (end position)	2 W
Wire sizing	5,5 VA
Control	Modbus RTU / analog (0)2...10 VDC / Ri > (100 kΩ) 50 kΩ (0)4...20 mA / Rext. = 500 Ω
Feedback signal	Modbus RTU / analog (0)2...10 VDC, max. 0,5 mA
Priority control	close / min / btw / max / open / stop
Connection motor	cable 1000 mm, 4 x 0,75 mm ² (halogen free)
Sensor	
Measuring range - dynamic version	500-1500 Pa
Measuring range - static version	400-600-1000 Pa
Burst pressure	1 bar
Nominal value damper manufacturer specific value	damper manufacturer specific value Vmin / Vbtw / Vmax based on Vnom
Media	air -40°C...85°C / 5...95% r.H., non condensing
Mounting position	independent of position
Connection	tube clip Ø 4-6 mm
Functional data	
Torque	5 -10 - 15 Nm
Synchronised speed	±5%
Direction of rotation	adjustable

Manual override	gear de-clutch with pushbutton, lockable
Angle of rotation	0°...max. 95° can be limited with adjustable mechanical end stops
Running time	5 Nm: 100 s / 90° (adjustable 20...120 s / 90°) 10 & 15 Nm: 150 s / 90° (adjustable 70...420 s / 90°)
Sound power level	< 35 dB(A) @ standard running time
Shaft coupling	universal clamp (Ø 20 mm) or form fit □ 8/10/12 mm
Position indication	mechanical with pointer
Service life	> 100 000 cycles (0°...95°...0°) > 1 500 000 partial cycles (max. ±5°)
Safety	
Protection class	III (safety extra-low voltage)
Degree of protection	IP 42 (cable downwards, tube clip connected) IP 20 (with screw terminals)
EMC	CE (2014/30/EU)
LVD	CE (2014/35/EU)
RoHS	CE (2011/65/EU - 2015/863/EU - 2017/2102/EU)
Mode of operation	Typ 1 (EN 60730-1)
Rated impulse voltage	0,5 kV (EN 60730-1)
Control pollution degree	3 (EN 60730-1)
Ambient temperature normal operation	0°C...+50°C
Storage temperature	-20°C...+80°C
Ambient humidity	5...95% r.H., non condensing (EN 60730-1)
Maintenance	maintenance free
Dimensions	
Dimensions	155 x 67 x 66 mm
Weight	5 Nm: 450 g 10/15 Nm: 550 g

- ▼ [Product overview](#)
- ▼ [Ordering key](#)
- ▼ [Accessories](#)
- ▼ [Actuators](#)
- ▼ [Parametrization](#)
- ▼ [Diagrams](#)
- ▼ [Maintenance](#)

ACTUATORS

Wiring diagram

VAV
 – variable operation min ... max
 -Mode 2-10V:
 Damper closed < 0,8 V (adjustable via WIN-VAV2 0,2 V ... 1,8 V)
 -Master/Slave circuit possible

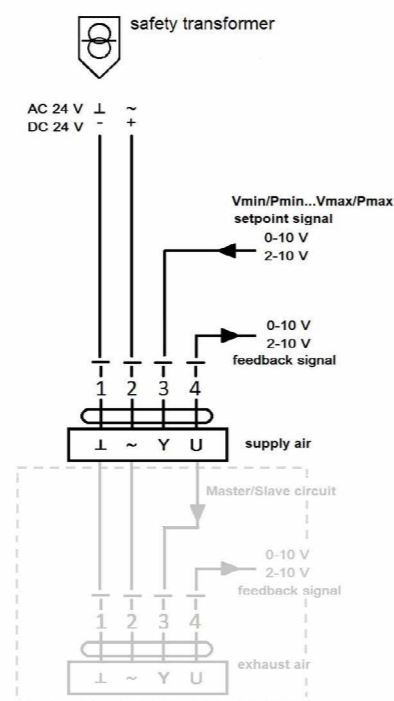

CAV
 – step operation close / min / btw / max / open

Signal/ Function	Min	Max	Btw	Open	Close
Open line	X				
GND (2.10 V)					X
Full wave		X		X	
Pos. Hal-wave				X	
Neg. Hal-wave					X

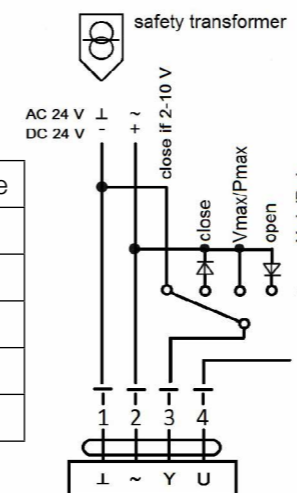

BELIMO ZTH

Adjustment device ZTH-EU for VAV terminal units with Belimo volume flow controllers, used to facilitate service and commissioning.

Service tool for parameterizable and communicative actuators / VAV controllers and HVAC performance devices from Belimo. Connection via service socket on the device or MP/PP connection ZIP USB function.

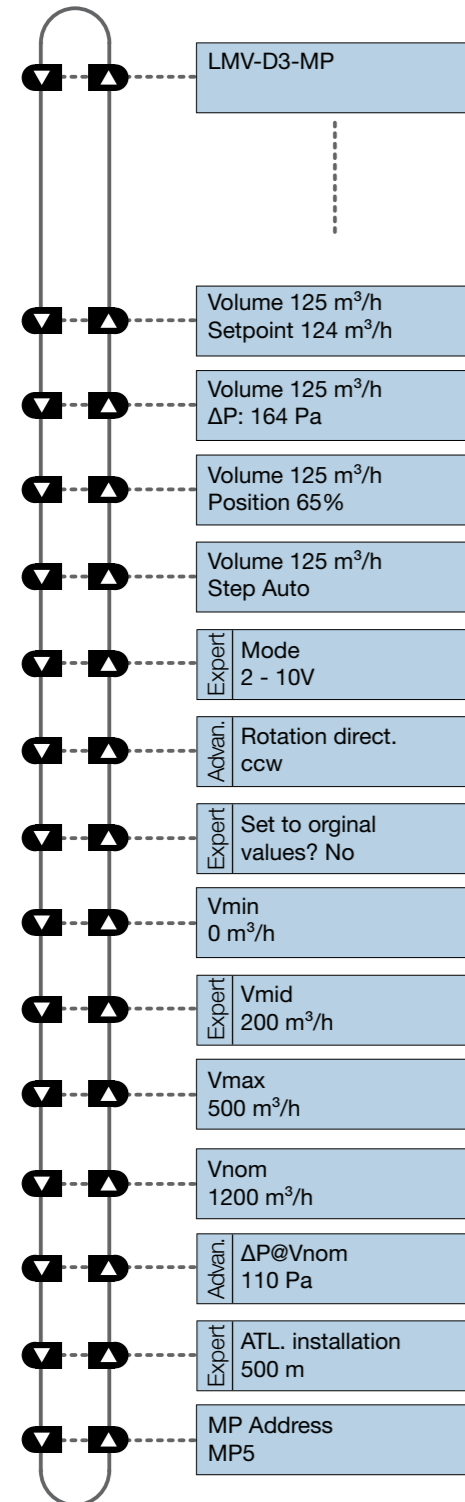

Instructions

Pressing the buttons , you scroll through the main menu. In order to prepare the selected values (parameters), it is necessary to follow the steps in the picture.

AUTO / OPEN / CLOSE / Min / Mid / Max / Stop

2 - 10V / 0 - 10V (only with MF/MP types)

ccw / cw

No / Yes

0...Vmax

Vmin...Vmax

Vmin...Vnom, minimum 20% of Vnom

0...3000 m

PP, MP1...MP8
(on MF types only PP)

- ▼ [Product overview](#)
- ▼ [Ordering key](#)
- ▼ [Accessories](#)
- ▼ [Actuators](#)
- ▼ [Parametrization](#)
- ▼ [Diagrams](#)
- ▼ [Maintenance](#)

↻ PARAMETRIZATION

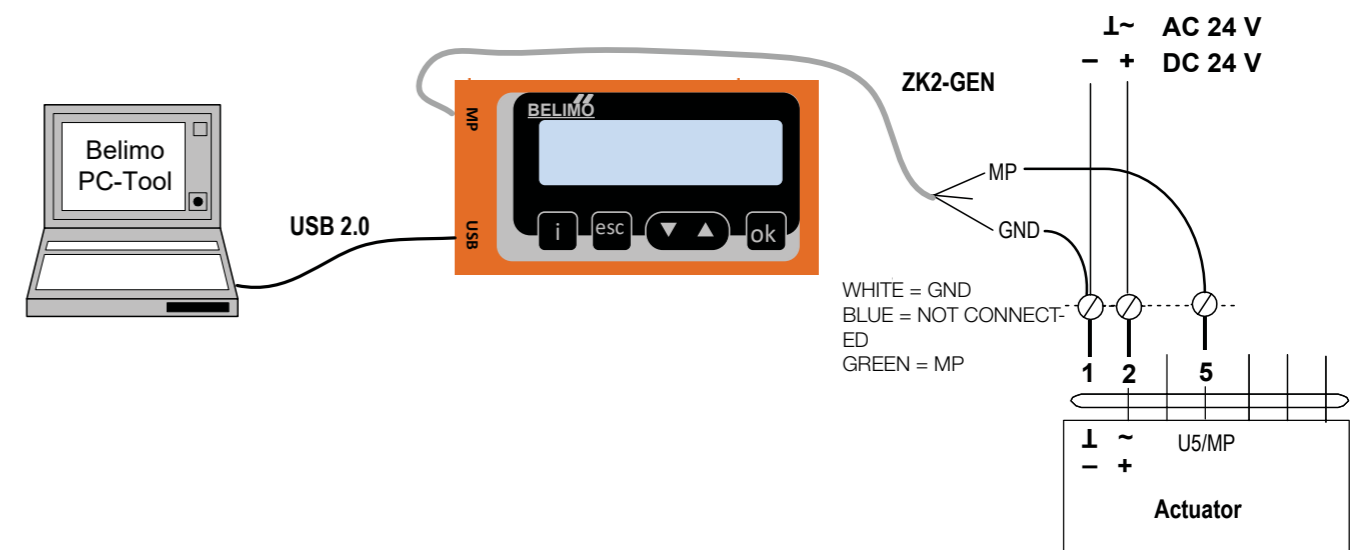

Gruner GUIV3-M

GUIV will start via on/off switch. If GUIV is connected to an actuator, the data will be read out and shown in the display. The control panel is used to set various operating modes, override controls and parameter settings. The GUIV features a micro USB. This allows to use the GUIV as an interface converter between WINVAV2 software and actuator or for loading a battery pack.

Instructions

To perform parameterization, it is necessary to connect the drive with the adjustment device GUIV3-M. The adjustment device contains a circular button and a confirmation button. With circular button you scroll through the main menu and you can change the values (parameters).

Menu points GUIV3-M

- 1.Act / Set
Shows actual value / setpoint (override function).
- 2.Min
Adjust the desired min value (setpoint Y = 0 / 2 V DC).
- 3.Max
Adjust the desired max value (setpoint Y = 10 V DC).
- 4.Diag
Diagnostic menu:
y/u – shows setpoint / feedback signal
off – return to first level
oP – opens the damper
cL – closes the damper
Hi – activates max. value
Lo – activates min. value
bE – activates between value
St – diagnostic mode on, motor off
Adp – adaption drive (only 15 Nm or Modbus version)
123 – software version
- 5.Mode
0An (0-10 VDC | normal direction of rotation) 2An (2-10 VDC | normal direction of rotation)
2Ai (0-10 VDC | inverse direction of rotation) 2Ai (2-10 VDC | inverse direction of rotation)
- 6.Com
Setting the Modbus address (1...247) and communication parameters (if Modbus version).
- 7.Nom
Volumetric air flow: Shows & setting the nominal value depending on the VAV-Box
Pressure: Setting the correction factor
- Settings
327 VAV actuators can be set directly on the display. All 327 VAV actuators can communicate via service connector with setting tool GUIV3-M or with setting software WIN-VAV2. GUIV3-S is used as an interface for setting software WIN-VAV2.
- Accessories
GUIV3-M – service connector + handheld tool GUIV3-M
WINVAV2-Bundle – service connector + PC interface GUIV3-S + setting software WIN-VAV2.

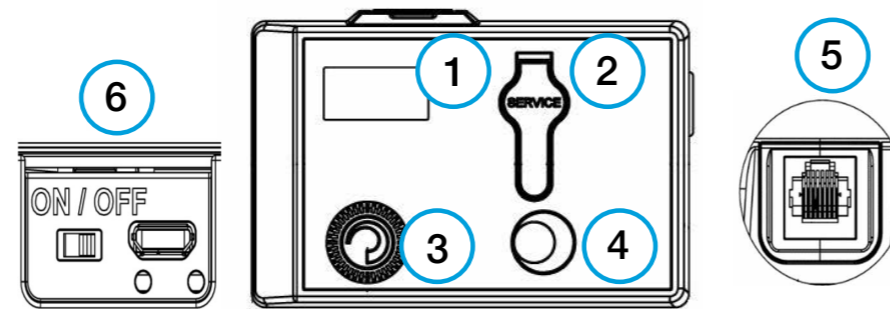

1. Display
2. Port for service-plug
3. Rotary selector switch
4. LED push button
5. RJ45 socket
6. On/off Switch and Micro-USB Interface

- ▼ [Product overview](#)
- ▼ [Ordering key](#)
- ▼ [Accessories](#)
- ▼ [Actuators](#)
- ▼ [Parametrization](#)
- ▼ [Diagrams](#)
- ▼ [Maintenance](#)

↻ PARAMETRIZATION

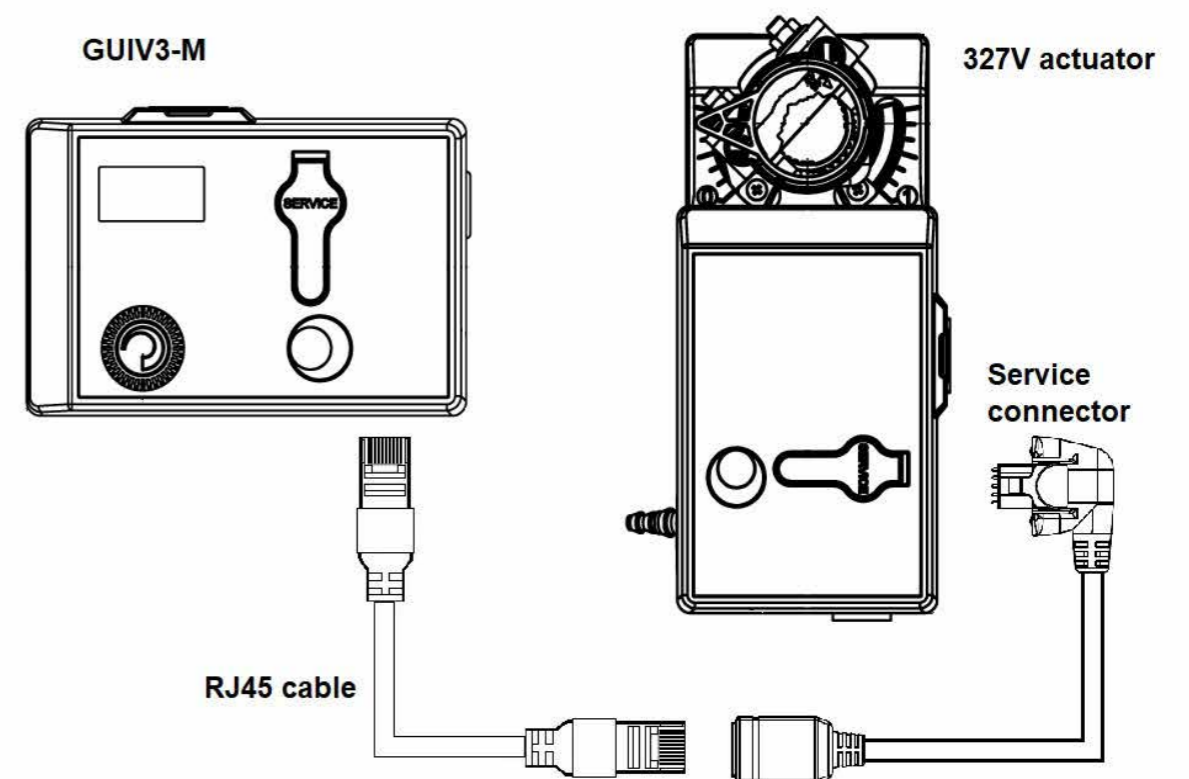

Siemens AST20

Instructions

Pressing the UP/DOWN buttons, you scroll through the main menu. Button ENTER opens submenu or allows changing the selected value using UP/DOWN button.

The pictures show the way of changing the values (parameters).

AST20 <> VAV Modbus	1/1 SVC
Online view	▶
Field device configuration	▶
Bus configuration	▶
Diagnostics and maintenance	▶
AST20 settings	▶
Mass configuration	▶

Field device configuration	1/2 SVC
Operating mode	VAV mode
Opening dir	CW
Adaptive pos	On
Vn value	2.04
Vmin	10%
Vmax	90%
Vnom	450 m3/h

Field device configuration	1/2 SVC
Operating mode	VAV mode
Opening dir	CW
Adaptive pos	On
Vn value	2.04
Vmin	10%
Vmax	90%
Vnom	450 m3/h

Field device configuration	1/2 SVC
Operating mode	VAV mode
Opening dir	CW
Adaptive pos	On
Vn value	2.04
Vmin	10%
Vmax	90%
Vnom	450 m3/h

AST20

1. AST20
2. G..B181.1E/.. , ASV181.1E/3, or G..B111../MO
3. Strain release strip
4. Connection cable (7-pin or 6-pin)

Handheld Tool for VAV Compact Controllers and Communicative Actuators.
For configuration and maintenance of OpenAir VAV compact and modular controllers and actuators with Modbus RTU communication

- ▼ [Product overview](#)
- ▼ [Ordering key](#)
- ▼ [Accessories](#)
- ▼ [Actuators](#)
- ▼ [Parametrization](#)
- ▼ [Diagrams](#)
- ▼ [Maintenance](#)

PARAMETRIZATION

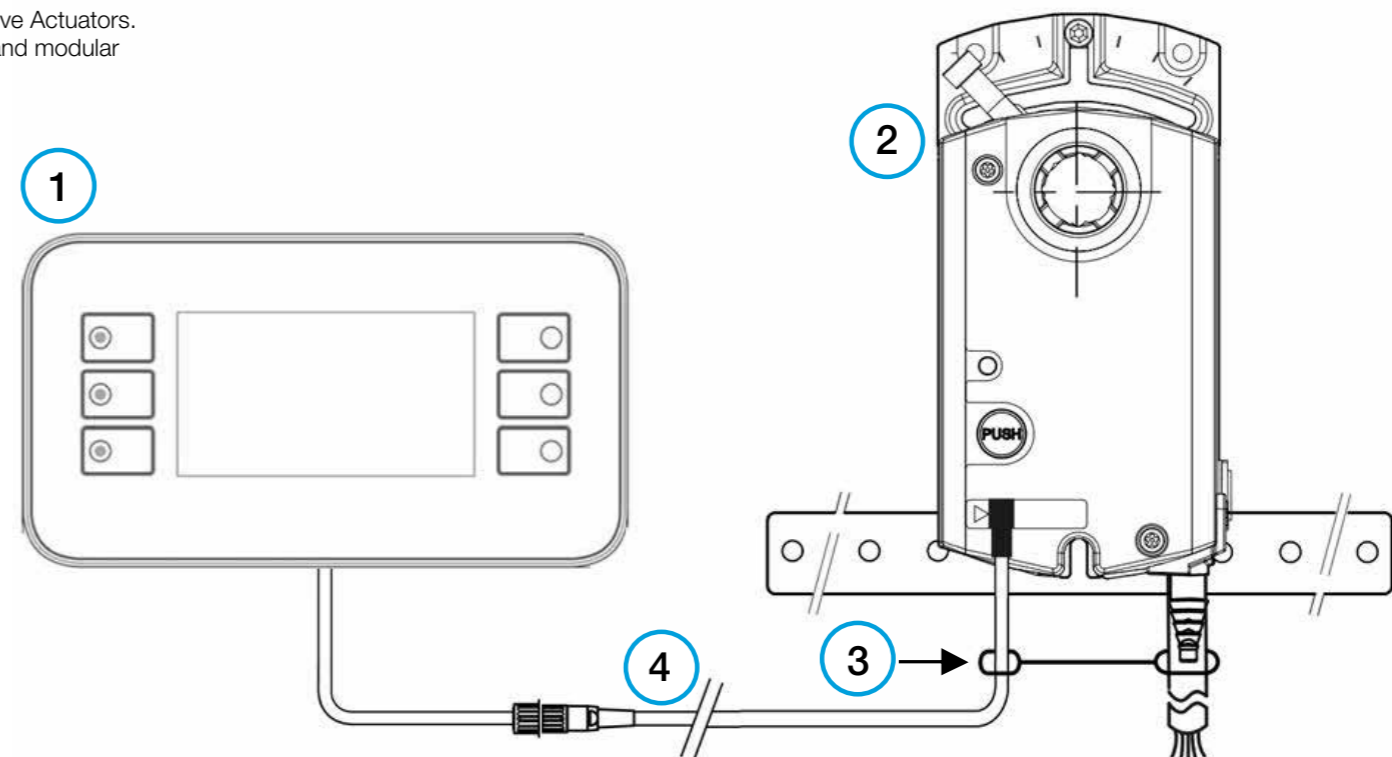

Sound and pressure drop CAVU

Air volume [m³/h]

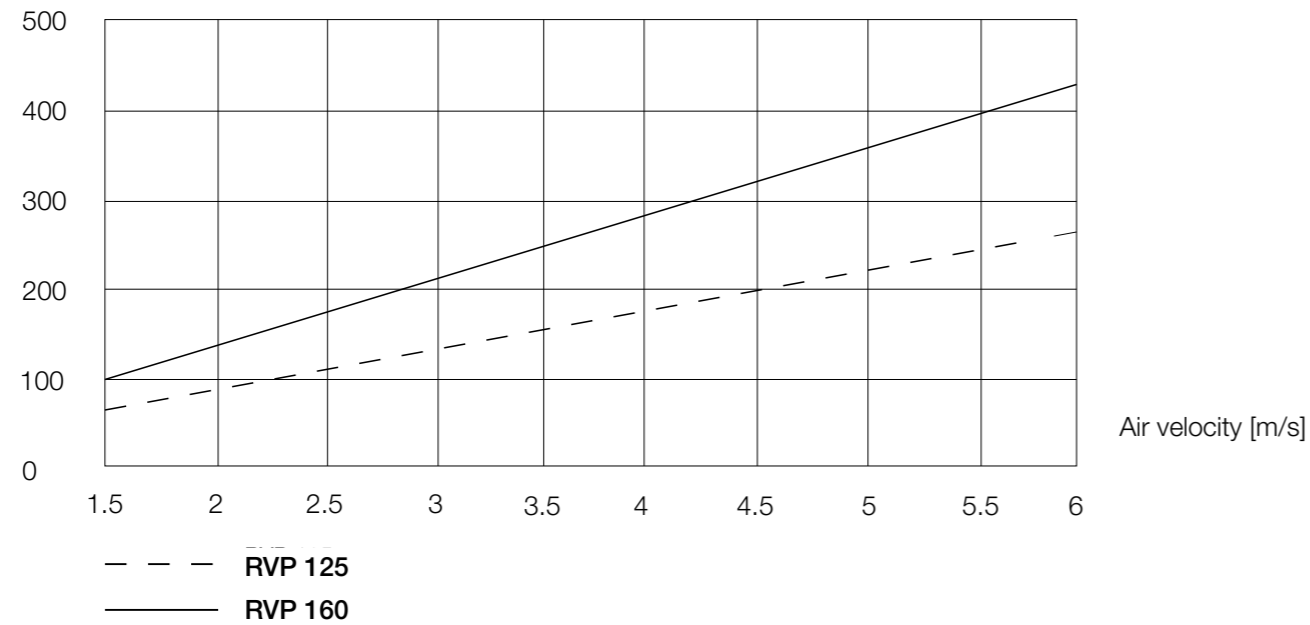

Lw[dB(A)]

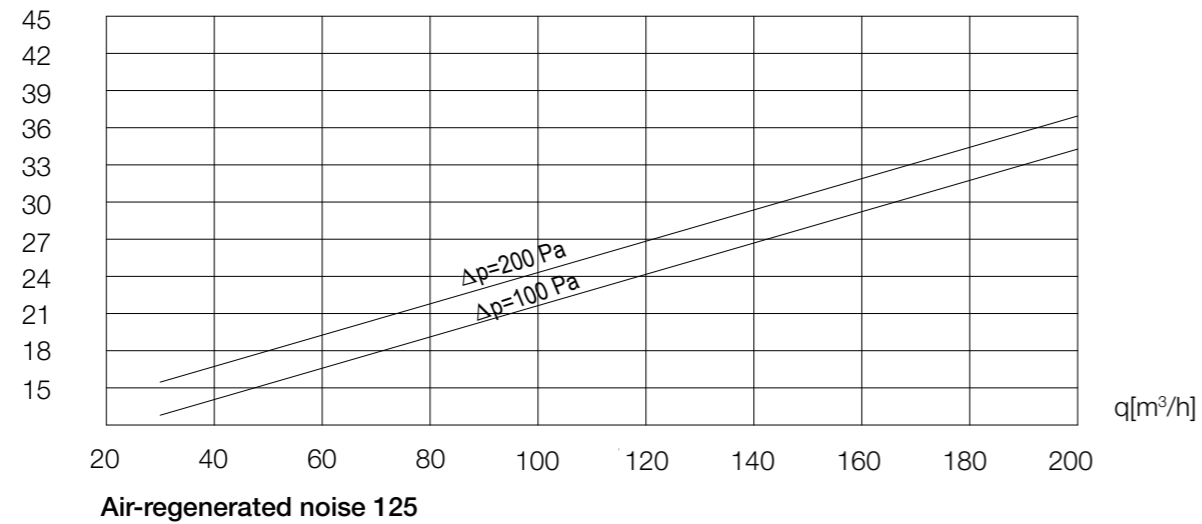

Lw[dB(A)]

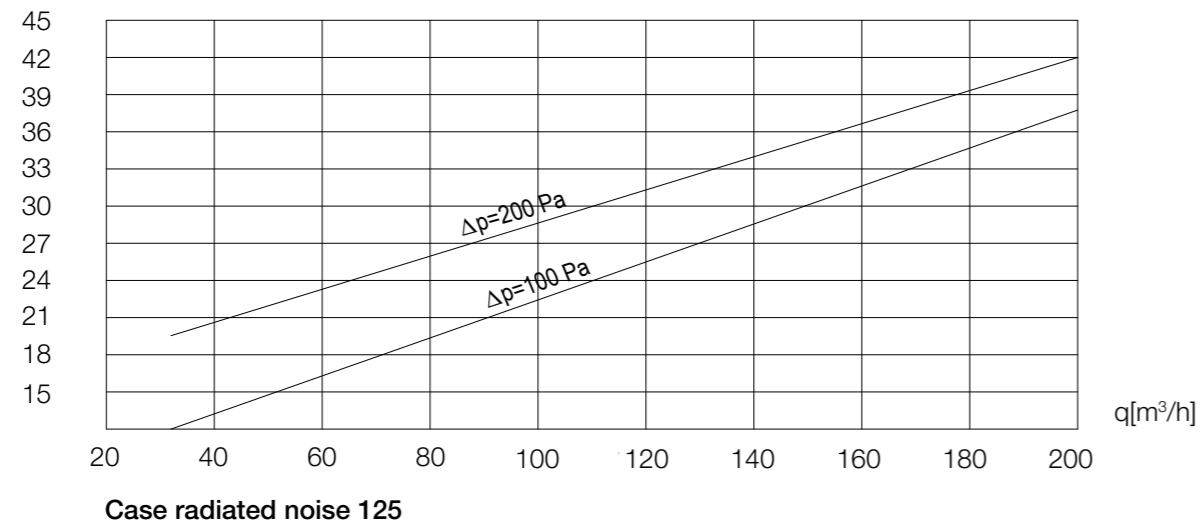

- ▼ [Product overview](#)
- ▼ [Ordering key](#)
- ▼ [Accessories](#)
- ▼ [Actuators](#)
- ▼ [Parametrization](#)
- ▼ [Diagrams](#)
- ▼ [Maintenance](#)



[SolveAir link](#)



DIAGRAMS

Sound and pressure drop CAVU

Nominal size	Volume flow		$\Delta p_t = 50 \text{ Pa}$								$\Delta p_t = 125 \text{ Pa}$								$\Delta p_t = 250 \text{ Pa}$											
	vL [m/s]	[m³/h]	Lw [dB/Oct]								LWA [dB(A)]	Lw [dB/Oct]								LWA [dB(A)]	Lw [dB/Oct]								LWA [dB(A)]	
			Hz									Hz									Hz									
			63	125	250	500	1000	2000	4000	8000		63	125	250	500	1000	2000	4000	8000		63	125	250	500	1000	2000	4000	8000		
ø 100	1	28	8	34	24	18	<16	<16	<16	<16	<16	18	34	26	19	<16	<16	<16	<16	<16	19	29	26	20	<16	<16	<16	<16	<16	19
	3	85	24	51	51	32	<16	<16	<16	<16	<16	35	55	54	32	19	<16	<16	<16	<16	36	53	52	38	27	<16	<16	<16	<16	36
	5	141	39	56	53	38	29	<16	<16	<16	<16	40	58	58	40	30	21	<16	<16	<16	41	62	63	44	31	21	<16	<16	<16	45
ø 125	1	44	12	45	38	24	<16	<16	<16	<16	<16	21	46	40	26	<16	<16	<16	<16	<16	23	44	40	26	17	<16	<16	<16	<16	25
	3	133	37	58	50	33	22	<16	<16	<16	<16	37	61	53	34	22	22	<16	<16	<16	39	62	58	40	27	<16	<16	<16	<16	42
	5	221	61	59	55	42	34	24	<16	<16	<16	41	61	57	44	34	34	<15	<15	<16	42	70	66	46	34	24	<16	<16	<16	50
ø 160	1	83	23	43	36	27	23	<16	<16	<16	<16	25	45	38	29	24	24	<16	<16	<16	27	43	37	28	24	<16	<16	<16	<16	26
	3	217	60	57	54	40	29	<16	<16	<16	<16	38	59	56	41	29	29	<16	<16	<16	40	60	54	47	39	22	<16	<16	<16	43
	5	362	101	60	55	45	36	28	17	<16	<16	42	62	58	47	37	37	19	<16	<16	44	67	65	51	41	29	19	<16	<16	49

- ▼ [Product overview](#)
- ▼ [Ordering key](#)
- ▼ [Accessories](#)
- ▼ [Actuators](#)
- ▼ [Parametrization](#)
- ▼ [Diagrams](#)
- ▼ [Maintenance](#)

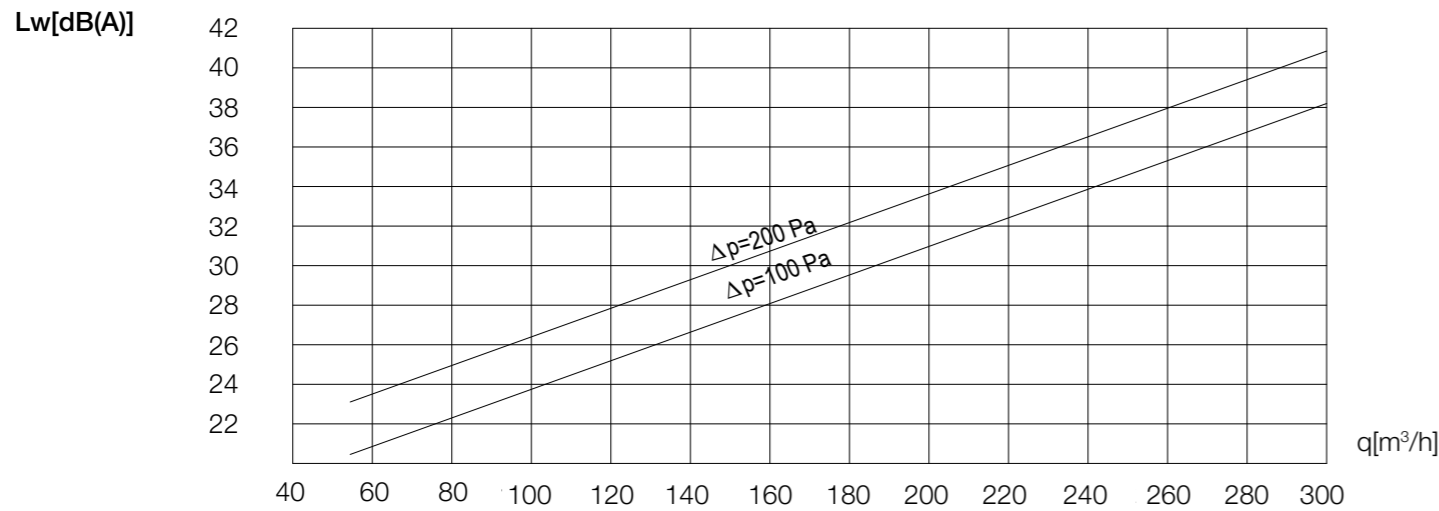

Air- regenerated noise 160

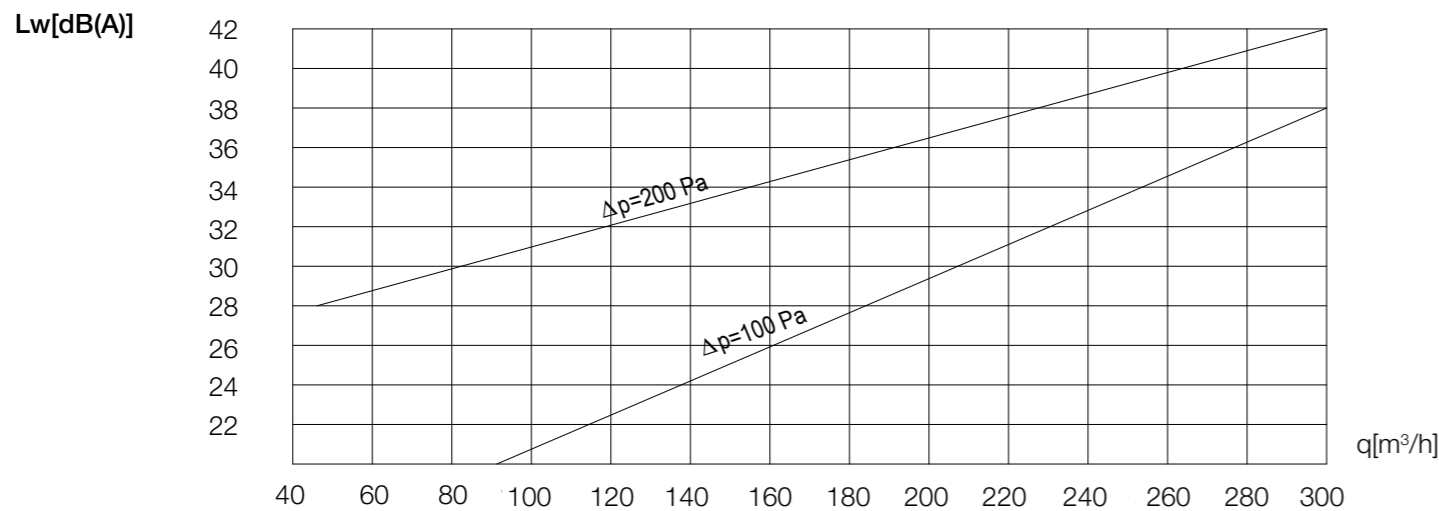

Case radiated noise 160

Lw [dB(A)] - Sound power level, flow noise
 vL [m/s] - Flow speed, air duct
 Δp_t [Pa] - Total pressure difference



[SolveAir link](#)





- ▼ [Product overview](#)
- ▼ [Ordering key](#)
- ▼ [Accessories](#)
- ▼ [Actuators](#)
- ▼ [Parametrization](#)
- ▼ [Diagrams](#)
- ▼ [Maintenance](#)



TRANSPORT

After arrival, check the CAVU unit for transport damage and shortcomings. In case of any damage or shortcomings, immediately contact your supplier.

STORAGE

If the CAVU unit is not installed immediately:

- Remove any wrapping.
- Protect CAVU unit from dust and contamination.
- Do not expose the CAVU unit to the effects of weather - store the CAVU unit in a dry place.
- Do not store the unit below -20 °C or above 50 °C.

Please properly dispose of packaging material!

MAINTENANCE AND OPERATION

Klimaoprema CAVU units are designed with fully enclosed drive mechanism outside of the duct and as such do not require cleaning and regular maintenance. However, activation mechanism should be inspected for proper operation on regular basis.

- After each intervention, provide a systematic cleaning of dust and especially the solenoid and its movable plate
- Check the if the electrical terminals are tightened
- Cleaning instruction: clean with a sponge, with water or a mild detergent
- Disinfection instruction: spray disinfectant (disinfectant may contain alcohol which is flammable, take precaution to avoid ignition)

It is not permitted to alter the dampers in any way nor perform any changes to their structure (except for the service procedures described in this manual) without the manufacturer's consent.

The functional test must be carried out in compliance with the basic maintenance principles of the European norms EN 13306, EN 15423 and EN15650.

COMMISSIONING

- Carefully unpack CAVU - be careful of sharp edges and do not use excessive force for unpacking
- Inspect the product - check the unit for damage
- Before commissioning: check the product functions

ACTUATORS

- Electric actuator



AIRFLOW REGULATION

Projektiranje, proizvodnja i održavanje opreme za klimatizaciju, ventilaciju i čiste prostore.
Design, production and service of Ventilation, Air-Conditioning and Clean room equipment.

 Gradna 78A, 10430 Samobor, Croatia
 +385 (0)1 33 62 513
 info@klimaoprema.com
 www.klimaoprema.com