



## RECTANGULAR FIRE DAMPER

FD



### DESCRIPTION

- **FD** - rectangular fire damper used for the isolation of duct penetrations between fire compartments.

OPTIONS:

**R** - manual drive fire damper

**R-S** - manual drive fire damper with 2 limit switches

**EMS-S** - electromagnetic drive, permanent, 2 limit switches

**EMP-S** - electromagnetic drive, interruptive, 2 limit switches

**M230-S** - electric actuator, 230V AC, 2 limit switches

**M24-S** - electric actuator, 24V DC, 2 limit switches

**M24-S-ST** - electric actuator, 24V DC, 2 limit switches

### FIRE PROTECTION

- **Fire resistance according to EN 1366-2, classified according to EN 13501-3, Declaration of performance given according to Annex III of Regulation No 305/2011**

- Rigid wall: EI 120 S (ve, i↔o)
- Flexible wall: EI 120 S (ve, i↔o)
- Ceiling / floor: EI 120 S (ho, i↔o)

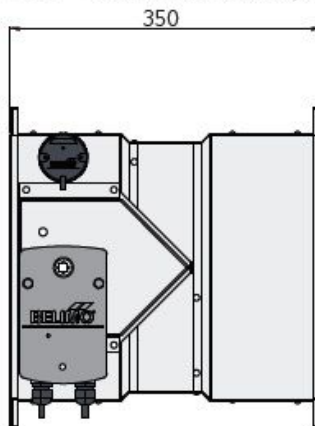
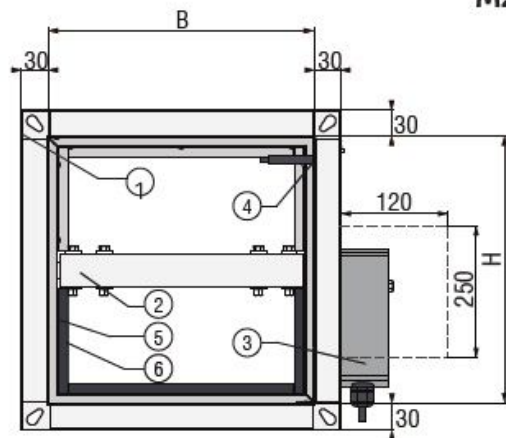

- 1 Fire damper housing
- 2 Damper blade
- 3 Electric actuator: Belimo BFL/BFN/BF
- 4 Thermo-electric tripping device(72°C)
- 5 Smoke seal
- 6 Intumescent strip

### Dimensions

| DIMENSIONS<br>MIN B(W) x H<br>[mm] | DIMENSIONS<br>MAX B(W) x H<br>[mm] |
|------------------------------------|------------------------------------|
| 100x200                            | 1500x800                           |

**NOTE:** All possible combinations of width and height are available. Standard dimensions are available with increments of 50mm.